

## KF-51 Specifications

Method	Volumetric Karl Fischer Titration
End point detection	Constant Current Polarization Potential Difference
Measurement range	0.1 mg to 999.999 mg H <sub>2</sub> O
Stirring method	Magnetic stirrer
Titration flask	150 mL
Display	5.7 inch Color LCD Touch Panel Moisture amount and unit, potential, message, lapsed time, moisture concentration value
Calculation	Concentration based on editable formula Statistical calculation, Recalculation
Buret	Syringe type: 5 mL Accuracy: ±0.01 mL (when dispensing 4 mL)
Data Files	1 × Factor file 4 × Sample Parameter files 99 × Measurement data
Printer	Thermal printer, Dot impact printer (option)
Connectable vaporizers	VA-300, VA-210 II, VA-230, VG-200 (option)
External I/O	USB-A : USB memory USB-B : PC connect with TV51 Electronic balance
Working environment	Temperature: 15 to 40°C Humidity: <85%, No condensation
Power supply	AC100/ 120/ 220/ 240V (50 /60Hz), 60VA DC 24V (when using commercial batteries)
Dimensions and weight	230 (W) × 350 (D) × 360 (H) mm Approx. 4.8 kg

### Dot Impact Printer



Paper	58 mm width
Digits	24
Power supply	AC115V, 230V
Dimensions and weight	106 (W) × 180 (D) × 88 (H) mm Approx. 0.5 kg

P/N: CAEPDB (115V), CAEPDC (230V)

### Thermal Printer



Paper	48 mm width
Power supply	AC115V, 230V
Dimensions and weight	78 (W) × 112 (D) × 59 (H) mm Approx. 0.18 kg

P/N: CK3PTA (115V), CK3PTC (230V)

### VA Power Unit



Dimensions and weight	310 (W) × 125 (D) × 100 (H) mm Approx. 1.5 kg
-----------------------	--

P/N: CA31PWF

Necessary when connecting VA-230 to CA/KF-51

**Note:** Follow instructions in manuals to correctly install, connect and operate the instruments. Contents of catalogues are subject to change without prior notice when improvements are made in performance. The actual color of the goods may appear different from color printed. All screen images are simulated. \*Company and product names contained herein are the trademarks or registered trademarks of the company concerned.

## CA-51 Specifications

Method	Coulometric Karl Fischer Titration
Titration control	Constant Current Pulse Time Control
End point detection	Constant Current Polarization Potential Difference
Electrolysis current	430 mA
Titration speed	Average 2.2 mg H <sub>2</sub> O/ min (36 µg H <sub>2</sub> O/ sec)
Background	Automatic Correction, Constant display Background level at start of measurement is displayed
Measurement range	10 µg to 999.9999 mg H <sub>2</sub> O
Sensitivity	0.1 µg H <sub>2</sub> O
Stirring method	Magnetic Stirrer
Repeatability	<0.3 % RSD at 1 mg or more H <sub>2</sub> O (n=10)
Display	5.7 inch Color LCD Touch Panel Moisture amount and unit, titration speed, background value, message, lapsed time, moisture concentration value
Calculation	Concentration based on editable formula, Statistical calculation, Recalculation
Data Files	5 × Sample Parameter files 99 × Measurement data
Printer	Thermal printer, Dot impact printer (option)
Connectable vaporizers	VA-300, VA-210 II, VA-230, VG-200 (option)
External I/O	USB-A : USB memory USB-B : PC connect with TV-51 Electronic balance
Working environment	Temperature: 15 to 40°C Humidity: <85%, No condensation
Power supply	AC100/ 120/ 220/ 240V (50 /60Hz), 60VA DC 24V (when using commercial batteries)
Dimensions and weight	220 (W) × 350 (D) × 360 (H) mm Approx. 3.7 kg

### Carrying Case



Dimensions and weight	340 (W) × 485 (D) × 500 (H) mm Approx. 1.5 kg
-----------------------	--

P/N: CA31CC

Moisture Meter KF-51

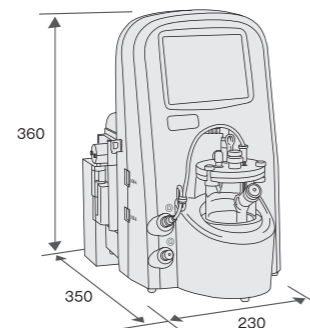

Moisture Meter CA-51

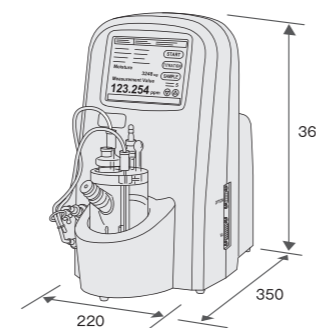

# Karl Fischer Moisture Meter CA-51/KF-51

### Automatic measurement start

Just inject samples. The unit detects the start of measurement automatically.

### Convertible (KF-51)

By exchanging volumetric flask and coulometric cell, covering full-range of moisture measurement

### PC viewer software, TV-51

Seamlessly transfer Text data (txt.) from CA-51/KF-51 to your PC. Effortlessly backup, restore and archive for data and settings



## Nittoseiko Analytech Co., Ltd.

7-10-1 Chuo-rinkan, Yamato, Kanagawa 242-0007, JAPAN

Tel: +81(0)46-278-0056

URL: <https://www.n-analytech.co.jp/global/>

CAT No.02140225041E

**Nittoseiko Analytech Co., Ltd.**

Portable type moisture meter with easy operation. It can be used in a variety of situations such as laboratories and manufacturing sites. This system can measure the moisture content of various samples such as foods, pharmaceuticals and various oils from trace to high concentration range. It is possible to analyze samples that are difficult to dissolve in reagents by connecting a vaporizer. This is an epoch-making moisture meter that performs two roles of volumetric titration and coulometric titration.



### Convertible

Model KF-51 initially comes with a titration flask for volumetric titration. By adding a coulometric cell, the same unit can be used as coulometric Karl Fischer instrument. No need to buy two instruments to cover all of your needs.



Moisture meter KF-51

Coulometric titration cell set

### Automatic measurement start function

This function detects sample injection and automatically start the measurement. No need to press the start button.



### Automatic reagent dispersing system

Dispose and dispense reagent with one push of button. Excluding catholyte in cathode chamber.

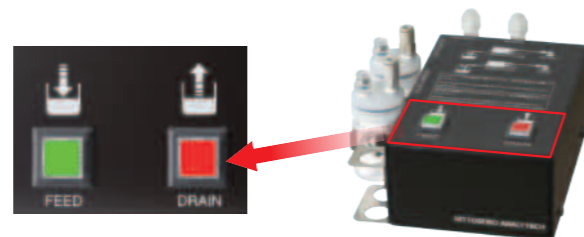

### Other functions

The measurement data can be written to USB memory as a text-format file. You can manage the output data with Excel® etc.

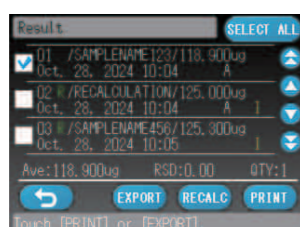

### Carrying Case

The light carrying case will hold the CA/KF-51 main unit and battery. Can be carried easily.



P/N: CA31CC

## Water vaporizers and other options

### VA-300 (Boat type)



Plastics, rubber, food, pharmaceutical, inorganic salts, other powders and solid samples

P/N: CK3VA

Heating temp	50 to 300°C
Heater	Transparent Conductive Glass 150W
Sample size	Up to 10 g
Measuring range	≥ 5 ppm (used with coulometric titration)
Carrier gas	Nitrogen, 0.1 to 0.5 L/min
Power supply	AC 100/120V (50/60 Hz) 160VA AC 220/240V (50/60 Hz) 740VA
Dimensions/Weight	325(W) × 170(D) × 260(H) mm, Approx. 4kg

### VA-230 (Vial type)



Place samples in a vial and measure. Suitable for plastics, rubber, food, pharmaceuticals, inorganic salt, etc.

P/N: VAE3B (115V)  
VAE3C (230V)

Heating temp	70 to 300°C
Heater	Aluminum Block Heater, 60W × 2
Sample size	Up to 10 g and volume 2.5 mL, Vial size 10 mL
Measuring range	≥ 30 ppm (used with coulometric titration)
Carrier gas	Nitrogen, 0.1 to 0.5 L/min
Power supply	AC 100/120V (50/60 Hz) 140VA AC 220/240V (50/60 Hz) 280VA
Dimensions/Weight	300(W) × 135(D) × 220(H) mm, Approx. 3.5 kg

### VA-210II (For lubricants)



Sample is dispersed and mixed in heated base oil. It makes quick and complete vaporization for viscous samples such as Lubricants, tar, etc.

P/N: VAE1F

Heating temp	70 to 200°C
Heater	Transparent Conductive Glass 200W
Sample size	Up to 50 g
Measuring range	≥ 5 ppm (used with coulometric titration)
Carrier gas	Nitrogen, 0.1 to 0.5 L/min
Power supply	AC 100/120V (50/60 Hz) 160VA AC 220/240V (50/60 Hz) 740VA
Dimensions/Weight	120(W) × 220(D) × 230(H) mm, Approx. 3kg

### Reagent Exchanging Unit



P/N: CA31SD2

Dimensions/ weight	103(W) × 150(D) × 69(H) mm, approx. 0.95kg
--------------------	--

### Reagent Bottle Holder



For 500 ml reagent bottle

P/N: KF8BTH

### Titration Viewer Model TV-51

TV-51 is software for connecting CA-51/KF-51 to a PC and loading the measurement data stored in CA-51 / KF-51 into the PC. You can easily create reports in PDF format from imported data.

This software allows you to view and display the measurement results from moisture meters CA-51 and KF-51 in Windows®.

Statistical calculation results (mean, standard-deviation, repeatability) and reports in which several measurement results can be stored in PDF form.

Security of the data and setting on CA-51/KF-51: TV-51 has functions, backup, restore and archive.

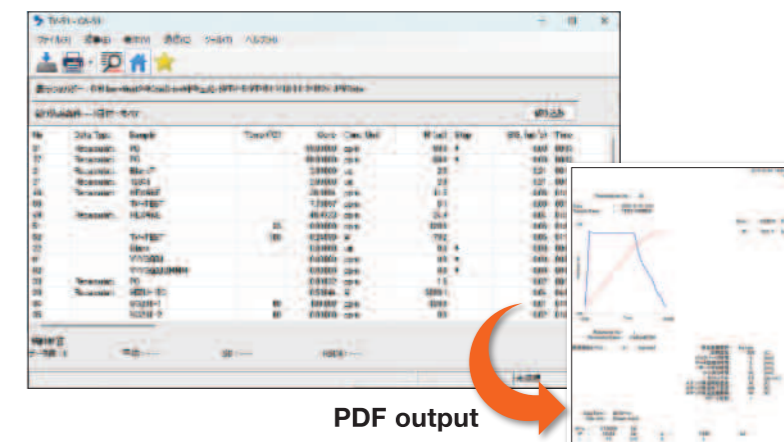

PDF output