

Evotech 7*** Series

Universal Hardness testing
systems



Universal systems of Evotech Series

Universal hardness testing systems are versatile instruments used to measure the hardness of materials. They can perform a variety of hardness tests, including Brinell, Vickers, Rockwell, Superficial rockwell and Knoop, as well as tests for plastics and carbon testing. These machines support a wide load range, typically from 0.3 to 3,000 kg, to accommodate different materials and component geometries across various industries.

One significant advantage of these machines is their ability to quickly switch between individual test methods without extensive machine conversion. This makes them a flexible solution for testing the hardness of a wide range of materials in both laboratory and production environments. The key components of a universal hardness testing machine include:

- + **Load Application Feature:** This is the mechanism that applies force to the indenter, which in turn presses into the material being tested.
- + **Indenter:** A hard object, often made of diamond or another hard material, that is pressed into the material to create an indentation.
- + **Test Anvil:** A support platform on which the test material is placed.
- + **Optical Evaluation System:** Used for examining the indentation made by the indenter to measure hardness.
- + **Depth Measurement System:** Measures the depth of the indentation, which is crucial for certain types of hardness tests.

These components work together to determine the hardness of a material by measuring its resistance to deformation under a standardized force. The universal nature of these machines allows them to perform multiple types of hardness tests, making them a versatile tool in material science and quality control processes.



9 Position precision Turret

Universal Evotech Series Models

	Evotech 7001	<i>EV-70H-7001</i>	5-3000kgf	Single indenter, BIOS, Excl screen
1	Evotech 7002	<i>EV-70H-7002</i>	5-3000kgf	Single indenter, BIOS, Incl screen
	Evotech 7003	<i>EV-70H-7003</i>	0.2-3000kgf	Rockwell, Vickers, Knoop, Brinell
	Evotech 7004	<i>EV-70H-7004</i>	0.2-3000kgf	Rockwell, Vickers, Knoop, Brinell
2	Evotech 7010	<i>EV-051-7010</i>	0.2-250kgf	Rockwell, Vickers, Knoop, Brinell
	Evotech 7012	<i>EV-051-7012</i>	0.2-750kgf	Rockwell, Vickers, Knoop, Brinell
	Evotech 7014	<i>EV-051-7014</i>	0.2-3000kgf	Rockwell, Vickers, Knoop, Brinell
3	Evotech 7020	<i>EV-091-7020</i>	0.5-250kgf	Rockwell, Vickers, Knoop, Brinell
	Evotech 7022	<i>EV-091-7022</i>	3-750kgf	Rockwell, Vickers, Knoop, Brinell
	Evotech 7024	<i>EV-091-7024</i>	5-3000kgf	Rockwell, Vickers, Knoop, Brinell
	Evotech 7026	<i>EV-091-7026</i>	3-3000kgf	Rockwell, Brinell
4	Evotech 7050	<i>EV-096-7050</i>	0.5-250kgf	Rockwell, Vickers, Knoop, Brinell
	Evotech 7052	<i>EV-096-7052</i>	0.2-250kgf	Rockwell, Vickers, Knoop, Brinell
	Evotech 7054	<i>EV-096-7054</i>	5-3000kgf	Rockwell, Vickers, Knoop, Brinell
	Evotech 7056	<i>EV-096-7056</i>	0.2-3000kgf	Rockwell, Vickers, Knoop, Brinell
5	Evotech 7080	<i>EV-098-7080</i>	0.5-250kgf	Rockwell, Vickers, Knoop, Brinell
	Evotech 7082	<i>EV-098-7082</i>	0.2-250kgf	Rockwell, Vickers, Knoop, Brinell
	Evotech 7084	<i>EV-098-7084</i>	5-3000kgf	Rockwell, Vickers, Knoop, Brinell
	Evotech 7086	<i>EV-098-7086</i>	0.2-3000kgf	Rockwell, Vickers, Knoop, Brinell
	Evotech 7088	<i>EV-098-7088</i>	3-3000kgf	Rockwell, Brinell

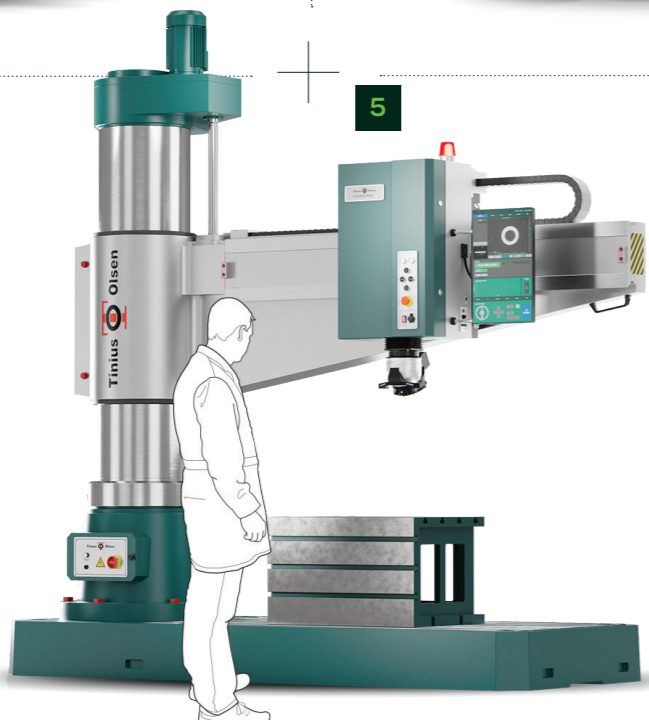

Model Evotech 701*

The model Evotech 701*, Rockwell, Vickers, Knoop and Brinell hardness tester provides exceptional performance, designed to match the most demanding user tasks. This tester contains a revolutionary force application range and renewed optical system.

The all new 9 position turret accommodates a wide range of indenters, indenter actuators with load cells, objectives, a cross-laser positioning system and a load cell supported touch probe. It also provides a base to the 18 megapixel full color measurement camera and 18 megapixel full color overview camera with variable field of view, motorized zoom and auto focus system.



Features and benefits

- + Multi loadcell, closed loop, force feedback system
- + Load range 10gf-3000kgf (0.1N-29kN)*
- + Meets or exceeds ISO, ASTM and JIS standards
- + 9 position tool changer (turret) with visual LED process indicators
- + 18 megapixel full color measurement camera, bright white LED TTL illumination
- + 18 megapixel full color sample image & stage overview camera
- + Automatic workpiece height detection
- + Top quality ABS replaceable body parts, no frame damage from falling objects
- + Horizon high performance PC-based camera indent measuring system. Automatic measurement of the indent on the industrial touch screen. Archive file, handle images and data on the tester or your network

Standard Accessories

- + 18MP HD indent viewing camera
- + Descending test head with collision detection
- + Four vibration dampers, Power cable
- + Certificate of calibration
- + Installation and user manual
- + Keyboard & Mouse

Force configuration options

Force range extension	Force range extension 10 - 200gf	<i>EV-051-0001</i>
	Force range extension 250 - 750kgf (EV-051-7010 model only)	<i>EV-051-0002</i>

Model Evotech 701*

Specifications

Item#	+ EV-051-7010 + EV-051-7012 + EV-051-7014
Hardness scales	Vickers, Knoop, Brinell, Rockwell
Load application	Load cell, force feedback, closed loop system
Load range	10gf to 3000kgf
Motorized turret	9 positions: 8 free to configure (8 for indenters or 8 for objectives), 1 fixed (for cross laser & touch probe)
Optical system	High definition, 18MP machine vision system
Objectives	0.7x, 2.5x, 5x, 10x, 20x, 40x, 60x, 100x
Overview camera (optional)	18MP optical zoom camera, field of view 40x30mm/140x100mm
Electronic system	High performance embedded micro system controller, MS windows®, 27" full color industrial touchscreen, automatic and manual measurement
Test loads	10, 15, 20, 25, 50, 100, 200, 300, 500gf, 1, 1.25, 2, 2.5, 3, 4, 5, 6.25, 7.8125, 10, 15, 15.625, 20, 30, 31.25, 40, 50, 60, 62.5, 80, 100, 120, 125, 150, 187.5, 250kgf
Brinell test range	HBW1/1, 1/1.25, 1/2.5, 1/5, 1/10, 1/30 HBW2.5/6.25, 2.5/15.625, 2.5/31.25, 2.5/62.5, 2.5/187.5 HBW5/25, 5/31.25, 5/62.5, 5/125, 5/250, 5/750 HBW10/100, 10/125, 10/250, 10/500, 10/1000, 10/1500, 10/3000
Vickers test range	HV0.010, 0.015, 0.020, 0.025, 0.050, 0.1, 0.2, 0.3, 0.5, 1, 2, 2.5, 3, 4, 5, 10, 20, 25, 30, 40, 50, 60, 100, 120, 150
Knoop test range	HK0.01, 0.02, 0.025, 0.05, 0.1, 0.2, 0.3, 0.5, 1, 2, 5
Rockwell pre and main load	10kgf and 60, 100, 150kgf
Superficial rockwell pre and main load	3kgf and 15, 30, 45kgf
Rockwell scales	A, B, C, D, E, F, G, H, K, L, M, P, R, S, V
Superficial rockwell scales	15N, 30N, 45N, 15T, 30T, 45T, 15W, 30W, 45W, 15X, 30X, 45X, 15Y, 30Y, 45Y
Test cycles	Fully automatic, automatic and manual

Model Evotech 701*

Specifications

Standards	complies to or exceeds ISO, ASTM, JIS (Nadcap)
Test for accuracy	<0.25% for test force 100gf to 3000kgf <0.5% for test force below 100gf
Display resolution	0.01HV, HK and HB
Hardness conversion	Rockwell, Superficial Rockwell, Vickers, Brinell, Knoop, Leeb & Tensile
Statistics	Total test, max, min, average, range, standard deviation, all in real time after each test
Data storage capacity	Internal and external mSSD, SSD or HDD
Connectivity	5 USB ports, RJ45 ethernet, LAN, W-LAN, RS232, Bluetooth, 5-axis CNC and motorized XY stage connector, Dual HDMI screen connectors
Dwell time setting	Default 10 seconds, user defined
Workpiece accommodation	150 x 230mm (HxD)
Machine dimensions	695 x 425 x 1100mm (WxDxH)
Weight	180kg (397lbs)
Operating temperature	10-35°C (50-95°F) non-condensing
Power consumption	100W
Power supply	100-240V AC, 50Hz/60Hz, single phase
Humidity	10-90%, non-condensing

*Calibration of scales is required prior to use. Please specify desired scales at the time of ordering

Model Evotech 701*

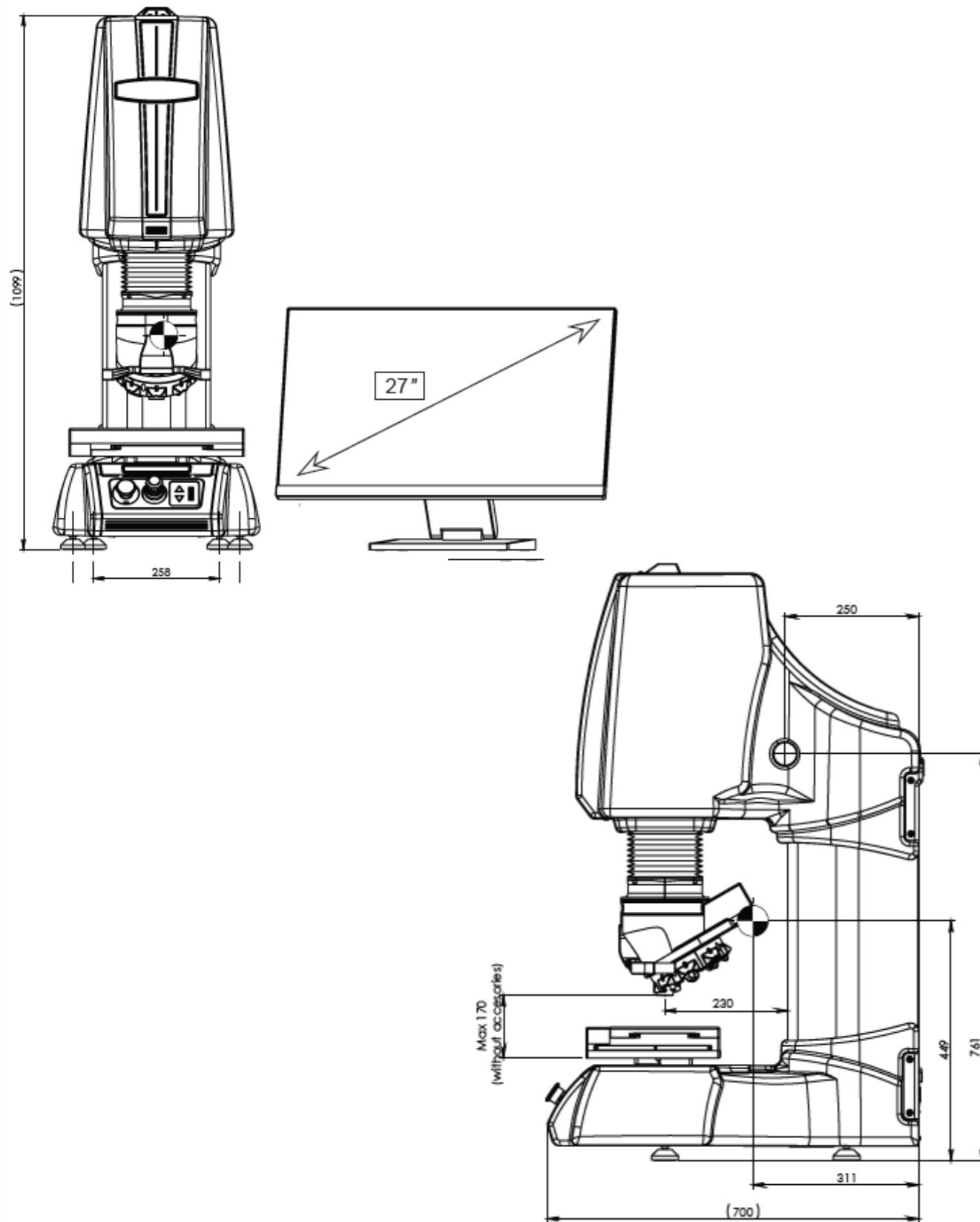

Model Evotech 702*

The model Evotech 702* is a heavy duty, rock solid C-frame with supreme rigidity. The closed loop system based on a load cell and Rockwell, Superficial Rockwell, Vickers, Knoop, Brinell, Ball indentation, HVT and HBT scales are part of testing capabilities.

The test force ranges from 200gf to 3000kgf and test cycles can be automatic or manual. With motorized 9 position turret, descending test head capable of workpiece detection, it is one of the most loaded technological hardness tester. 22" industrial touch screen and PC based Horizon software added advantage for this equipment.



Features and benefits

- + Multi loadcell, closed loop, force feedback system
- + Load range 200gf-3000kgf (1.96N-29kN)*
- + Meets or exceeds ISO, ASTM and JIS standards
- + 9 position turret with visual LED process indicators
- + Descending test head with automatic workpiece detection
- + 18Mpx measurement camera & 18Mpx overview camera
- + HD optical system for images of 0.7x to 1000x magnification
- + PC based Horizon Hardness testing firmware and database file system, standard
- + Large, adjustable 22" industrial touch screen
- + Automatic or manual focus, manual or fully automatic indent measurement, standard
- + Testing procedure and results storage on embedded drive
- + LAN, WLAN, USB-2, RS232, printer and DVI connectivity, standard
- + On board built-in driver for (optional) motorized XY stage, standard

* Configurations - as per table below

Standard Accessories

- + Motorized turret with 8 positions including cross laser touch probe
- + Built-in 3 axis support driver
- + Power cable
- + Certificate of calibration
- + Installation and user manual
- + Keyboard & Mouse

Force configuration options

Force range extension	Code
Force range extension 200 - 500gf	<i>EV-091-0001</i>
Force range extension 200gf - 3kgf	<i>EV-091-0002</i>
Force range extension 1 - 5kgf	<i>EV-091-0003</i>
Force range extension 200gf - 5kgf	<i>EV-091-0004</i>

Model Evotech 702*

Specifications

Item#	+ EV-091-7020 + EV-091-7022 + EV-091-7024 + EV-091-7026
Hardness scales	Rockwell, Superficial Rockwell, Vickers, Knoop, Brinell, Ball indentation, HVT, HBT
Load application	Load cell, force feedback, closed loop system
Load range	200gf to 3000kgf
Motorized turret	9 positions: 8 free to configure (8 for indenters or 8 for objectives), 1 fixed (for cross laser & touch probe)
Optical system	High definition, 18MP machine vision system
Objectives	0.7x, 2.5x, 5x, 10x, 20x
Indenters	Rockwell diamond cone: 120° Rockwell balls: 1/16in, 1/8in, 1/4in, 1/2in Brinell balls: 1mm, 2.5mm, 5mm, 10mm
Display	22" full color industrial touchscreen, testing results, statistics
Display resolution	0.01HV, HK and HB
Standards	complies to or exceeds ISO, ASTM, JIS (Nadcap)
Test cycles	Motorized, automatic, pre-load, load, dwell, unload process
Brinell test range	HBW1/1, 1/1.25, 1/2.5, 1/5, 1/10, 1/30, 1/31.25 HBW2.5/6.25, 2.5/15.625, 2.5/31.25, 2.5/62.5, 2.5/187kgf HBW5/25, 5/31.25, 5/62.5, 5/125, 5/250, 5/750 HBW10/100, 10/125, 10/250, 10/500, 10/1000, 10/1500, 10/3000
HVD (HVT)	HV5,10, 20, 25, 30, 40, 50, 60, 100, 120, 150
HBD (HBT)	HBT1/5, 1/10, 1/30kgf HBT2.5/6.25, 2.5/15.625, 2.5/31.25, 2.5/62.5kgf HBT5/25, 5/31.25, 5/62.5, 5/125kgf HBT10/100, 10/125kgf
Vickers test range	HV0.2, 0.3, 0.5, 1, 2, 2.5, 3, 4, 5, 10, 20, 25, 30, 40, 50, 60, 100, 120, 150
Knoop test range	HK0.2, 0.3, 0.5, 1, 2, 5
Rockwell pre and main load	10kgf and 60, 100, 150kgf
Superficial rockwell pre and main load	3kgf and 15, 30, 45kgf

Model Evotech 702*

Specifications

Rockwell scales	A, B, C, D, E, F, G, H, K, L, M, P, R, S, V
Superficial rockwell scales	15N, 30N, 45N, 15T, 30T, 45T, 15W, 30W, 45W, 15X, 30X, 45X, 15Y, 30Y, 45Y
Test for accuracy	<0.25%
Connectivity	LAN, W-LAN, USB-3, Bluetooth (optional)
Workpiece accommodation	300 x 225mm (HxD)
Machine dimensions	510 x 710 x 1500 mm (WxDxH)
Weight	280kg (617lbs)
Operating temperature	10-35°C (50-95°F) non-condensing
Power consumption	100W
Power supply	100-240V AC, 50Hz/60Hz, single phase
Humidity	10-90%, non-condensing

*Calibration of scales is required prior to use. Please specify desired scales at the time of ordering

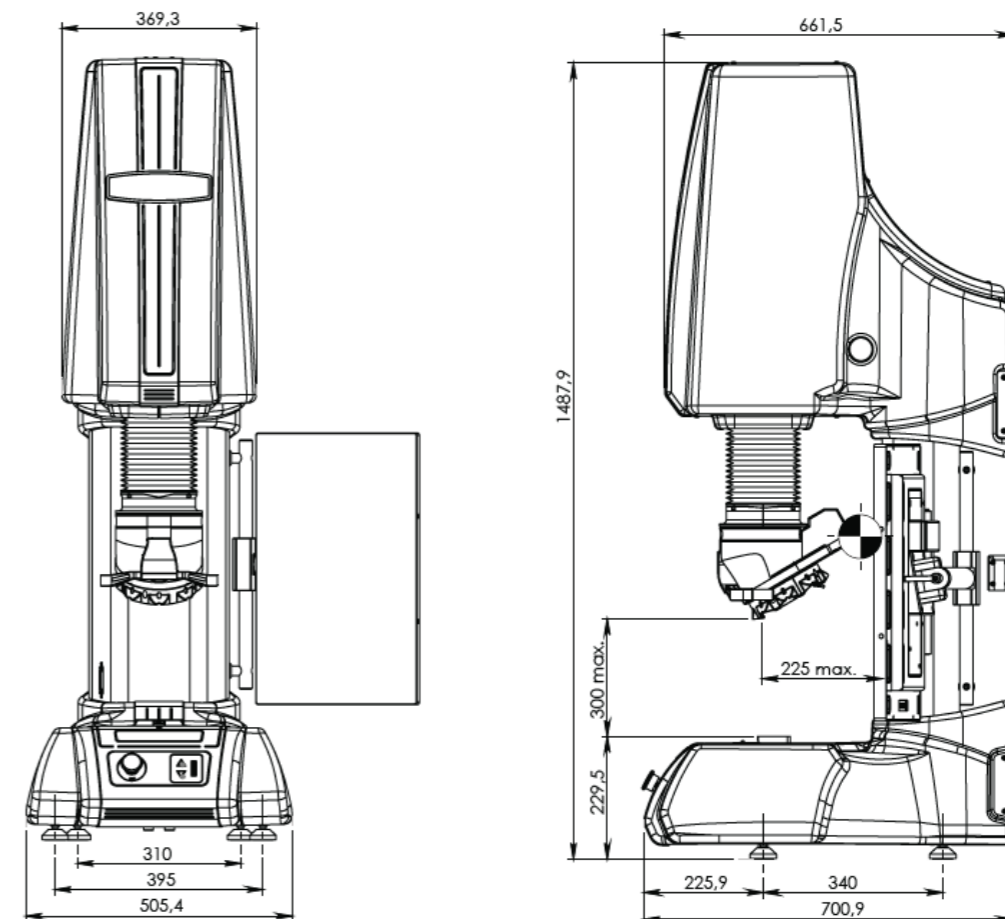

Model Evotech 705*

The model Evotech 705* is a heavy duty, rock solid C-frame with supreme rigidity. The closed loop system based on a load cell and Rockwell, Vickers, Knoop, Brinell, Ball indentation, HVT and HBT scales are part of testing capabilities.

The test force ranges from 200gf to 3000kgf and test cycles can be automatic or manual. With motorized Z axis, descending test head capable of workpiece detection and motorized 8 position turret, it is one of the most loaded technological Hardness tester. 15" industrial touch screen and PC based Horizon software added advantage for this equipment.



Features and benefits

- + Loadcell, closed loop, force feedback system
- + Load range 200gf-3000kgf (1.96N-29kN)*
- + Meets or exceeds ISO, ASTM and JIS standards
- + Z-axis with ball bearing spindle
- + Descending test head with automatic workpiece detection
- + 3 indenter positions, 3 LWD objectives installed (included)
- + HD optical system for images of 0.7x to 1000x magnification
- + PC based Horizon Hardness testing firmware and database file system, standard
- + Large, adjustable 15" industrial touch screen
- + Automatic or manual focus, manual or fully automatic indent measurement, standard
- + Testing procedure and results storage on embedded drive
- + LAN, WLAN, USB-2, RS232, printer and DVI connectivity, standard
- + On board built-in driver for (optional) motorized XY stage, standard
- + Free definable test patterns case depth, traverse, free style, etc, optional
- + Raise and lower up to 800kg specimen (standard)

* Configurations - as per table below

Standard Accessories

- + T-slot testing table 650x500mm
- + Motorized turret with 8 positions including cross laser touch probe.
- + Objectives for 0.7x, 2.5x and 10x magnification
- + Built-in 3 axis support driver
- + Power cable
- + Certificate of calibration
- + Installation and user manual
- + Keyboard & Mouse

Force configuration options

Force range extension	High force extension 500kgf & 750kgf for Brinell and ball indentation (EV-096-7052)	<i>FH-500-0033</i>
------------------------------	---	--------------------

Model Evotech 705*

Specifications

Item#	+ <i>EV-096-7050</i> + <i>EV-096-7052</i> + <i>EV-096-7054</i> + <i>EV-096-7056</i>
Hardness scales	Rockwell, Vickers, Knoop, Brinell, Ball indentation, HVT, HBT
Load application	Load cell, force feedback, closed loop system
Load range	200gf to 3000kgf
Motorized turret	8 position, 3 indenter, 3 objective positions
Optical system	High definition, 18MP machine vision system
Objectives	0.7x, 2.5x, 5x, 10x, 20x, 40x, 60x, 100x
Indenters	Rockwell diamond cone: 120° Rockwell balls: 1/16in, 1/8in, 1/4in, 1/2in Brinell balls: 1mm, 2.5mm, 5mm, 10mm
Display	15" full color industrial touchscreen, testing results, statistics
Display resolution	0.01HV, HK and HB
Standards	complies to or exceeds ISO, ASTM, JIS (Nadcap)
Test cycles	Motorized, automatic, pre-load, load, dwell, unload process
Brinell test range	HBW1/1, 1/1.25, 1/2.5, 1/5, 1/10, 1/30kgf HBW2.5/6.25, 2.5/15.625, 2.5/31.25, 2.5/62.5, 2.5/187kgf HBW5/25, 5/31.5, 5/62.5, 5/125, 5/187.5, 5/250kgf HBW10/100, 10/125, 10/250, 10/750, 10/1000, 10/1500, 10/3000kgf
HVD (HVT)	HV0.2, 0.3, 0.5, 1, 2, 2.5, 3, 4, 5, 10, 20, 25, 30, 40, 50, 100, 120, 150
HBD (HBT)	HBT1/1, 1/1.25, 1/2.5, 1/5, 1/10, 1/30kgf HBT2.5/6.25, 2.5/15.625, 2.5/31.25, 2.5/62.5, 2.5/187.5kgf HBT5/25, 5/31.25, 5/62.5, 5/125, 5/187.5, 5/250kgf HBT10/100, 10/125, 10/250, 10/750, 10/1000, 10/1500, 10/3000kgf
Vickers test range	HV0.2, 0.3, 0.5, 1, 2, 2.5, 3, 4, 5, 10, 20, 25, 30, 40, 50, 60, 100, 120, 150
Rockwell pre and main load	10kgf and 60, 100, 150kgf
Superficial rockwell pre and main load	3kgf and 15, 30, 45kgf
Rockwell scales	A, B, C, D, E, F, G, H, K, L, M, P, R, S, V
Superficial rockwell scales	15N, 30N, 45N, 15T, 30T, 45T, 15W, 30W, 45W, 15X, 30X, 45X, 15Y, 30Y, 45Y
Test force tolerance	<0.25%

Model Evotech 705*

Specifications

Connectivity	LAN, W-LAN, USB-3, Bluetooth (optional)
Workpiece accommodation	650 x 395mm (HxD)
Machine dimensions	540 x 1000 x 2120 mm (WxDxH)
Weight	800kg (1764lbs)
Operating temperature	10-35°C (50-95°F) non-condensing
Power consumption	426W
Power supply	100-240V AC, 50Hz/60Hz, single phase
Humidity	10-90%, non-condensing

*Calibration of scales is required prior to use. Please specify desired scales at the time of ordering

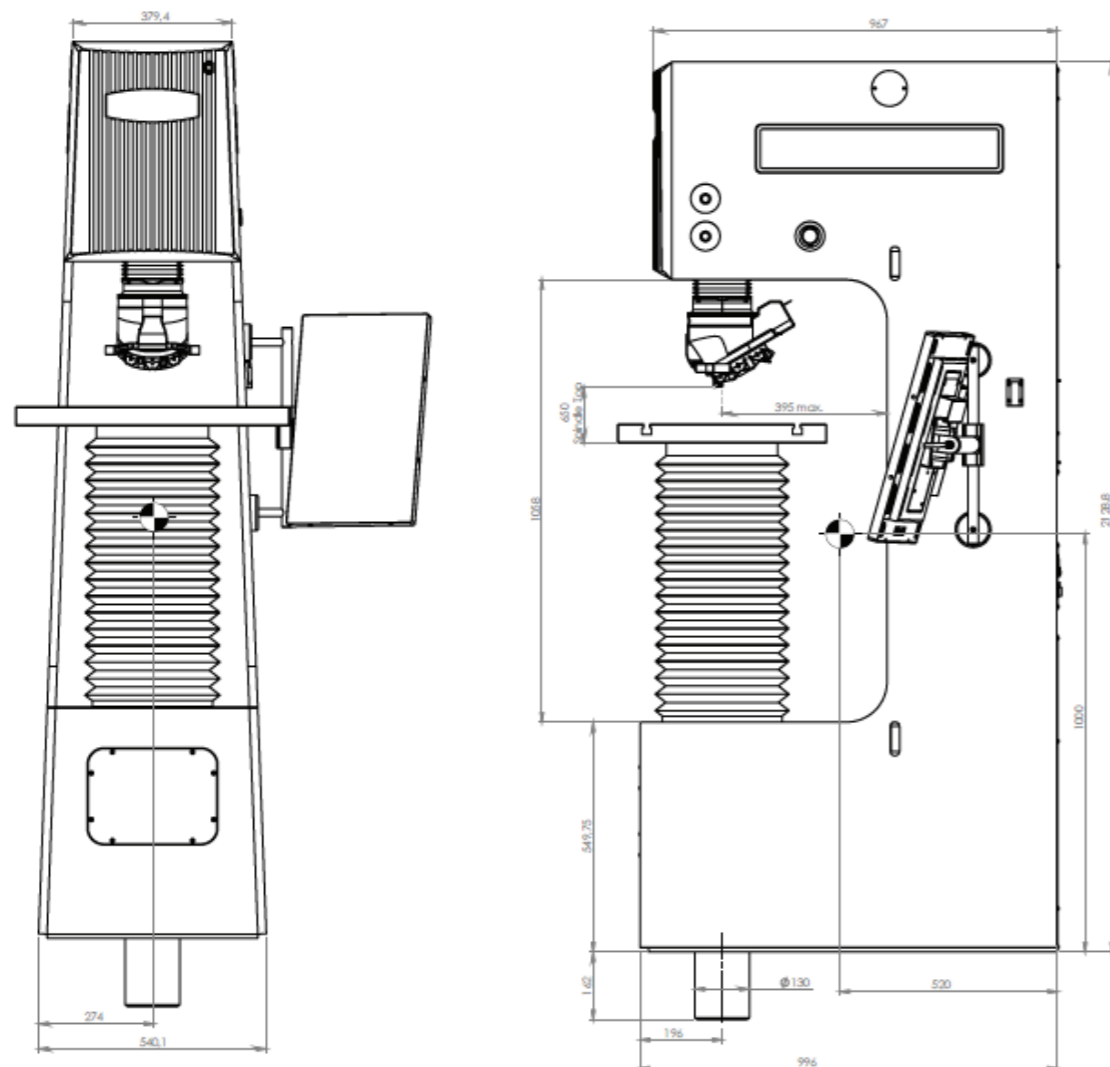

Model Evotech 708*

The model Evotech 708* is a large radial frame that allows testing either on the machine base or beside it. The heavy-duty test head easily pivots, ensuring seamless positioning of workpieces without any hindrance. Forget the hassle of manual workpiece adjustments. Use a crane or forklift truck to effortlessly position your parts. With its unique dual Z-axis, this tester provides an impressive range of test scales. From Vickers 500gf to Brinell 3000kgf, this tester can determine the hardness of objects ranging from small to remarkably large. The standard delivered removable cast iron block stage makes it convenient to test smaller parts at an ergonomic working height, ensuring precision and ease of use.

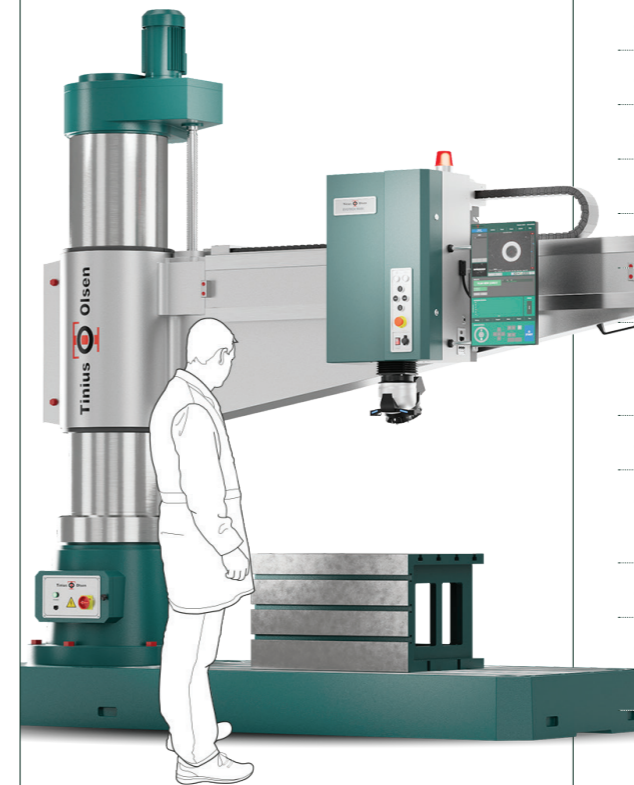

Features and benefits

- + Multi loadcell, closed loop, force feedback system
- + Load range 200gf-3000kgf (1.96N-29kN)*
- + Meets or exceeds ISO, ASTM and JIS standards
- + Z-axis with ball bearing spindle
- + Descending test head with automatic workpiece detection
- + 9 position turret with visual LED process indicators
- + 18MP measurement camera+18MP overview camera
- + PC based Horizon Hardness testing firmware and database file system, standard
- + Large, adjustable 22" industrial touch screen
- + Automatic or manual focus, manual or fully automatic indent measurement, standard
- + Testing procedure and results storage on embedded drive
- + LAN, WLAN, USB-2, RS232, printer and DVI connectivity, standard
- + On board built-in driver for (optional) motorized XY stage, standard
- + Free definable test patterns case depth, traverse, free style, etc, optional

* Configurations - as per table below

Standard Accessories

- + Motorized turret with 9 positions
- + Power cable
- + Certificate of calibration
- + Installation and user manual
- + Keyboard & Mouse

Force configuration options

Force range extension	High force extension 500kgf & 750kgf for Brinell and ball indentation (EV-098-7082)	FH-500-0033
-----------------------	---	-------------

Model Evotech 708*

Specifications

Item#	+ EV-098-7080 + EV-098-7082 + EV-098-7084 + EV-098-7086 + EV-098-7088
Hardness scales	Rockwell, Vickers, Knoop, Brinell, Ball indentation, HVT, HBT
Load application	Load cell, force feedback, closed loop system
Load range	200gf to 3000kgf
Motorized turret	9 positions: 8 free to configure (8 for indenters or 8 for objectives), 1 fixed (for cross laser & touch probe)
Optical system	HD 18MP machine vision system; 18MP overview camera
Objectives	0.7x, 2.5x, 5x, 10x, 20x
Indenters	Rockwell diamond cone: 120° Rockwell balls: 1/16in, 1/8in, 1/4in, 1/2in Brinell balls: 1mm, 2.5mm, 5mm, 10mm
Display	22" full color industrial touchscreen, testing results, statistics
Display resolution	0.01HV, HK and HB
Standards	complies to or exceeds ISO, ASTM, JIS (Nadcap)
Test cycles	Motorized, automatic, pre-load, load, dwell, unload process
Brinell test range	HBW1/1, 1/1.25, 1/2.5, 1/5, 1/10, 1/30, 1/31.25kgf HBW2.5/6.25, 2.5/15.625, 2.5/31.25, 2.5/62.5, 2.5/187kgf HBW5/25, 5/31.5, 5/62.5, 5/125, 5/250, 5/750kgf HBW10/100, 10/125, 10/250, 10/500, 10/1000, 10/1500, 10/3000kgf
HVD (HVT)	HV5, 10, 20, 25, 30, 40, 50, 60, 100, 120, 150
HBD (HBT)	HBT1/5, 1/10, 1/30kgf HBT2.5/6.25, 2.5/15.625, 2.5/31.25, 2.5/62.5, 2.5/187.5kgf HBT5/25, 5/31.25, 5/62.5, 5/125, 5/250kgf HBT10/100, 10/125, 10/250kgf
Vickers test range	HV0.5, 1, 2, 2.5, 3, 4, 5, 10, 20, 25, 30, 40, 50, 60, 100, 120, 150
Rockwell pre and main load	10kgf and 60, 100, 150kgf
Superficial rockwell pre and main load	3kgf and 15, 30, 45kgf
Rockwell scales	A, B, C, D, E, F, G, H, K, L, M, P, R, S, V
Superficial rockwell scales	15N, 30N, 45N, 15T, 30T, 45T, 15W, 30W, 45W, 15X, 30X, 45X, 15Y, 30Y, 45Y

Model Evotech 708*

Specifications

Test force tolerance	<0.25%
Connectivity	LAN, W-LAN, 5xUSB, Bluetooth, Dual HDMI connector
Workpiece accommodation	1500 x 1500mm (HxD)
Machine dimensions	3225 x 1250 x 3250 mm (WxDxH)
Weight	6,800kg (15,000lbs)
Operating temperature	10-35°C (50-95°F) non-condensing
Power consumption	426W
Power supply	100-240V AC, 50Hz/60Hz, single phase
Humidity	10-90%, non-condensing

*Calibration of scales is required prior to use. Please specify desired scales at the time of ordering

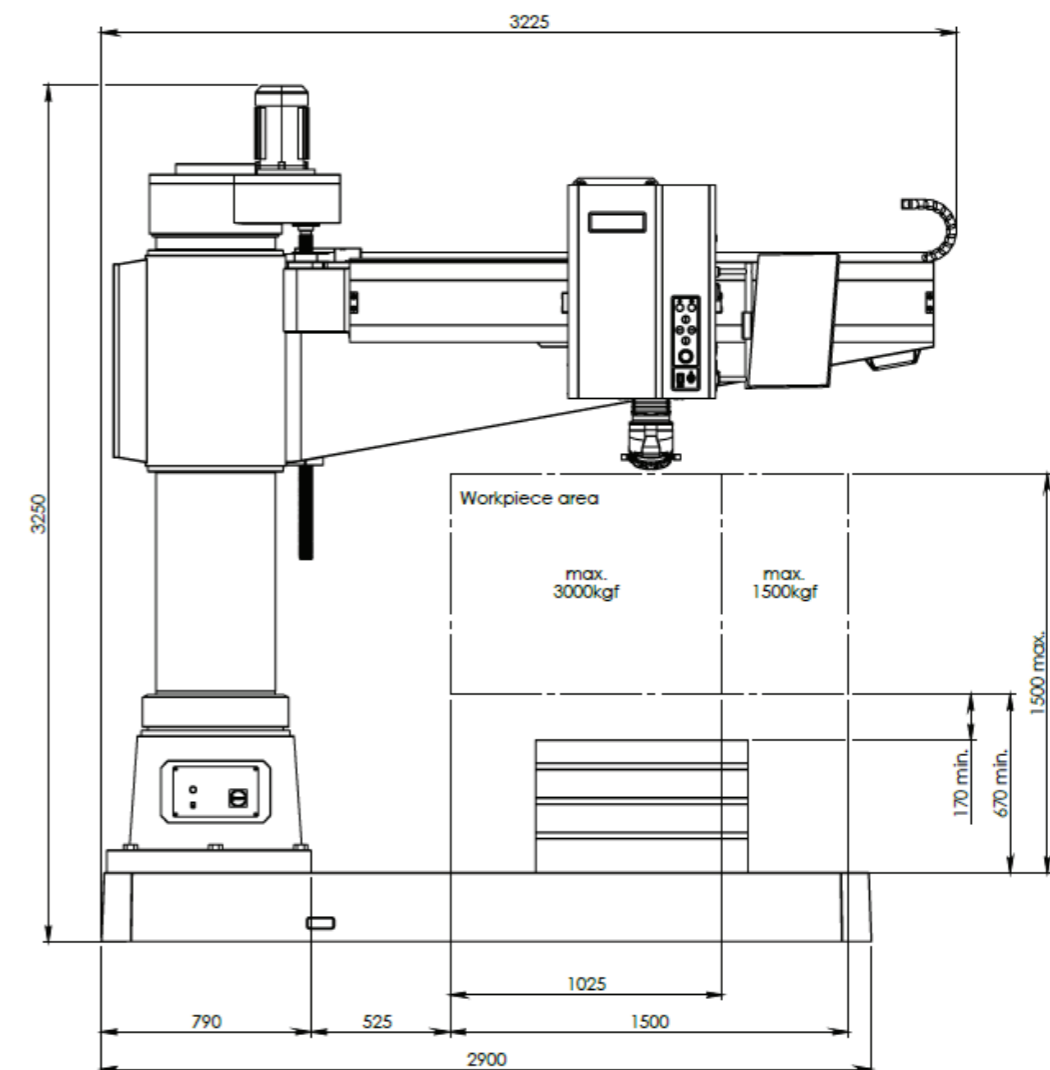

Model Evotech 700*

The model Evotech 700*, test heads can be supplied with integrated or external (table or floor mounted) operating console. The test heads can be fully integrated in product manufacturing lines. The closed loop system based on a load cell and Rockwell, Vickers, Knoop, Brinell, Ball indentation, HVT and HBT scales are part of testing capabilities.

The test force ranges from 200gf to 3000kgf and test cycles can be automatic or manual. With motorized Z axis, descending test head capable of workpiece detection and motorized 9 position turret, it is one of the most loaded technological Hardness tester. 15" industrial touch screen and PC based Horizon software added advantage for this equipment.

Features and benefits

- + Loadcell, closed loop, force feedback system
- + Load range 200gf-3000kgf (1.96N-29kN)*
- + Meets or exceeds ISO, ASTM and JIS standards
- + Descending test head with automatic workpiece detection
- + PC based Horizon Hardness testing firmware and database file system, standard
- + Large, adjustable 15" industrial touch screen
- + Automatic or manual focus, manual or fully automatic indent measurement, standard
- + Testing procedure and results storage on embedded drive

Standard Accessories

- + Motorized turret with 9 positions (EV7003 & EV7004)
- + Power cable
- + Certificate of calibration
- + Installation and user manual
- + Keyboard & Mouse



(EV7001 & EV7002)



(EV7003 & EV7004)

Model Evotech 700*

Specifications

Item#	+ EV-70H-7001 + EV-70H-7002 + EV-70H-7003 + EV-70H-7004
Hardness scales	Rockwell, Vickers, Knoop, Brinell, Ball indentation, HVT, HBT
Load application	Load cell, force feedback, closed loop system
Load range	200gf to 3000kgf
Motorized turret	9 position(for EV7003 & EV7004), Single indenter(for EV7001 & EV7002)
Display	15" full color industrial touchscreen, testing results, statistics
Display resolution	0.01HV, HK and HB
Standards	complies to or exceeds ISO, ASTM, JIS (Nadcap)

Optional accessories

Indenter seats

EV-LTP-0000	Cross laser & touch probe base	EV701*, EV702*, EV708*
EV-LTP-0001	Touch probe for laser base, closed	EV701*, EV702*, EV708*
EV-LTP-0002	Touch probe for laser base, open	EV701*, EV702*, EV708*
EV-INS-0000	Indenter seat 3mm, 10gf - (62.5 kgf)(187.5kgf)	EV701*
EV-INS-0001	Indenter seat adjustment base, mounting set	EV701*, EV702*, EV708*
EV-INS-0002	Fixed indenter seat base, mounting set (min. 1 required)	EV701*, EV702*
EV-INS-0003	Indenter seat 6.35mm, (3kgf) (5kgf) - 750kgf	EV701*
EV-INS-0004	Indenter seat 6.35mm, 1kgf - 250kgf	EV701*, EV702*, EV708*
EV-INS-0005	Indenter seat 6.35mm, 200gf - 62.5kgf	EV701*, EV702*, EV708*
EV-INS-0006	Fixed indenter seat base 6.35 mm, 3000kg	EV702*, EV708*
EV-INS-0007	Indenter seat 6.35mm, 200gf - 20kgf	EV702*

Indenters

FH-200-0054	Rockwell Ball Indenter 1/16". Includes 1 carbide ball Ø3mm. ISO & ASTM certified	EV701*, EV702*, EV705*, EV708*
FH-200-0055	Rockwell Ball Indenter 1/8". Includes 1 carbide ball Ø3mm. ISO & ASTM certified	EV701*, EV702*, EV705*, EV708*
FH-200-0056	Rockwell Ball Indenter 1/4". Includes 1 carbide ball. Ø3mm. ISO & ASTM certified	EV701*, EV702*, EV705*, EV708*
FH-200-0057	Rockwell Ball Indenter 1/2". Includes 1 carbide ball. Ø3mm. ISO & ASTM certified	EV701*, EV702*, EV705*, EV708*
FH-200-1002	Rockwell C Diamond Indenter. Ø3mm. ISO & ASTM certified acc. ISO 6508/2 & ASTM	EV701*, EV702*, EV705*, EV708*
FH-200-1008	Brinell Indenter 1mm. Includes 1 carbide ball. Ø3mm. ISO & ASTM certified	EV701*
FH-200-1009	Brinell Indenter 2.5mm. Includes 1 carbide ball. Ø3mm. ISO & ASTM certified	EV701*
FH-200-1010	Brinell Indenter 5mm. Includes 1 carbide ball. Ø3mm. ISO & ASTM certified	EV701*
FH-200-1019	Brinell Indenter 1mm. Incl: 1 carbide ball ISO 6506/2 & ASTM-E10 A3 (17mm)	EV701*, EV702*, EV705*, EV708*
FH-200-1020	Brinell Indenter 2.5mm. Incl: 1 carbide ball. ISO 6506/2 & ASTM-E10 A3 (17mm)	EV701*, EV702*, EV705*, EV708*
FH-200-1021	Brinell Indenter 5mm. Incl: 1 carbide ball ISO 6506/2 & ASTM-E10 A3 (17mm)	EV701*, EV702*, EV705*, EV708*

Optional accessories

FH-200-1022	Brinell Indenter 10mm. Incl: 1 carbide ball ISO 6506/2 & ASTM-E10 A3 (17mm)	EV701*, EV702*, EV705*, EV708*
FH-200-1023	1/16" carbide ball acc. to ISO 6508/2 & ASTM-E18 A3	EV705*
FH-200-1024	1/8" carbide ball acc. to ISO 6508/2 & ASTM-E18 A3	EV705*
FH-200-1025	1/4" carbide ball acc. to ISO 6508/2 & ASTM-E18 A3	EV705*
FH-200-1026	1/2" carbide ball acc. to ISO 6508/2 & ASTM-E18 A3	EV705*
FH-200-1027	1.0mm carbide ball Spare acc. to ISO 6506/2 & ASTM-E10 A3	EV705*
FH-200-1028	2.5mm carbide ball Spare acc. to ISO 6506/2 & ASTM-E10 A3	EV705*
FH-200-1029	5.0mm carbide ball Spare acc. to ISO 6506/2 & ASTM-E10 A3	EV705*
FH-200-1030	10.0mm carbide ball Spare acc. to ISO 6506/2 & ASTM-E10 A3	EV705*
FH-200-1000	Micro Vickers Indenter Ø3mm, ISO & ASTM certified	EV701*
FH-200-1001	Micro Knoop Indenter Ø3mm, ISO & ASTM certified	EV701*
FH-200-1011	Macro Vickers Indenter Ø6.35mm, ISO & ASTM certified	EV701*, EV702*, EV705*, EV708*
FH-200-1012	Macro Knoop Indenter Ø6.35mm, ISO & ASTM certified	EV701*, EV702*, EV705*, EV708*

Optical

EV-CAM-0000	Overview / Full view zoom camera + software functionality, Includes overview lights	EV705*
EV-CAM-0001	HD Overview camera. Full view zoom camera + software functionality	EV708*
EV-CAM-0003	Overview / Full view zoom camera + software functionality, field of view 57x60mm up to 225x180mm, Includes overview lights	EV701*, EV702*
EV-OBJ-0000	0.7x Objective for Brinell	EV701*, EV705*
EV-OBJ-0001	BRILIGHT objective 0.7x	EV702*, EV708*
EV-OBJ-0010	Adjustable objective socket 2.5x – 100x (1x required for each objective)	EV701*, EV702*, EV708*
EV-OBJ-0011	Adjustable objective socket 0.7x (required for 0.7 objective)	EV701*, EV702*, EV708*
FH-050-0211	2.5x Long Working Distance objective	EV701*, EV702*, EV705*, EV708*
FH-050-0212	5x Long Working Distance objective	EV701*, EV702*, EV705*, EV708*
FH-050-0213	10x Long Working Distance objective	EV701*, EV702*, EV705*, EV708*

Optional accessories

FH-050-0214	20x Long Working Distance objective	EV701*, EV702*, EV705*, EV708*
FH-006-1005	40x Long Working Distance objective	EV701*, EV705*
FH-006-1006	60x Long Working Distance objective	EV701*, EV705*
FH-006-1007	100x Long Working Distance objective	EV701*, EV705*
EV-RIL-0000	Crystal™ Clear LED ring light, multi use for 0.7x objectives	EV701*, EV705*
FH-050-0356	Crystal™ Clear LED ring light, multi use for 2.5x objectives	EV701*, EV702*, EV705*, EV708*
FH-050-0358	Crystal™ Clear LED ring light, multi use for 5x objectives	EV701*, EV702*, EV705*, EV708*
Stage/Anvil		
FH-050-0036	Manual X-Y stage with analogue metric micrometers, 180x160mm Displacement: 25x25mm, scale 0.01mm, max load 300kg	EV701*, EV702*, EV708*
FH-050-0279	Mounting plate for lock flange	EV701*, EV702*, EV708*
FH-050-0312	Mounting plate for lock flange	EV705*
FH-050-0285	Quick change anvil base (required for mounting testing tables, anvils)	EV701*, EV702*, EV708*
FH-050-0042	Testing table at ø200mm, screwfix	EV701*, EV702*, EV708*
FH-050-0034	Testing table at ø235mm, screwfix	EV701*, EV702*, EV708*
EV-RTT-0000	Testing table Ø200mm (61 - 65HRC) requires lock flange	EV701*, EV702*, EV708*
FH-050-0066	Manual X-Y stage with analogue metric micrometers, 100x100mm. Displacement: 25x25mm, scale 0.01mm, max load 100kg	EV701*, EV702*
FH-011-0018	Large at surface testing table 450x350mm, thickness 35mm with 2 T-slots, for large components	EV701*, EV702*, EV708*
FH-011-0038	Large flat surface testing table 350x250mm, thickness 30mm with 2 T-slots, for large components	EV701*, EV702*, EV708*
FH-050-0010	Digital micrometer, for manual X-Y stage, Displacement: 25mm, resolution 0.001mm	EV701*, EV702*
EV-MSA-0001	Manual iSMART™ stage, 150x150mm, Displacement: 50x50mm	EV701*, EV702*
EV-MSA-0002	Digital control unit for Manual iSMART™ stage, 25mm travel	EV701*, EV702*
EV-MSA-0003	Digital control unit for Manual iSMART™ stage, 50mm travel	EV701*, EV702*

Optional accessories

EV-MSA-0001	iSMART™ motorized CNC X-Y stage, 215x160mm, total load up to 400Kgf max. Displacement: 75x75mm, resolution 0.001mm, repeatability +/- 0.015mm	EV701*, EV702*, EV708*
EV-MSA-0002	iSMART™ stage, 260x205mm, total load up to 400Kgf max. Displacement: 120x120mm, resolution 0.001mm, repeatability +/- 0.015mm	EV701*, EV702*, EV708*
EV-MSA-0003	iSMART™ stage, 360x205mm, total load up to 400Kgf max. Displacement: 220x120mm, resolution 0.001mm, repeatability +/- 0.015mm	EV701*, EV702*, EV708*
EV-MSA-0004	iSMART™ stage, 490x224mm, total load up to 400Kgf max. Displacement: 340x120mm, resolution 0.001mm, repeatability +/- 0.015mm	EV701*, EV702*, EV708*
EV-MSA-0005	iSMART™ stage, 410x265mm, total load up to 4000Kgf max. Displacement: 200x150mm, resolution 0.001mm, repeatability +/- 0.015mm	EV701*, EV702*, EV708*
EV-MSA-0006	iSMART™ stage, 510x265mm, total load up to 4000Kgf max. Displacement: 300x150mm, resolution 0.001mm, repeatability +/- 0.015mm	EV701*, EV702*, EV708*
EV-MSA-0007	iSMART™ stage, 560x265mm, total load up to 4000Kgf max. Displacement: 400x150mm, resolution 0.001mm, repeatability +/- 0.015mm	EV701*, EV702*, EV708*
FH-049-0001	Motorized CNC X-Y stage, 307x208 mm, total load up to 400Kgf max Displacement: 170x120mm, resolution 0.001mm, repeatability +/- 0.003mm	EV701*, EV705*
FH-049-0002	Motorized CNC X-Y stage, 357x208 mm, total load up to 400Kgf max Displacement: 220x120mm, resolution 0.001mm, repeatability +/- 0.003mm	EV701*, EV702*, EV705*
FH-049-0012	Motorized CNC X-Y stage, 237x188mm, total load up to 100Kgf max Displacement: 100x100mm, resolution 0.001mm, repeatability +/- 0.003mm	EV705*
FH-049-0013	Motorized CNC X-Y stage, 257x188mm, total load up to 400Kgf max Displacement: 120x120mm, resolution 0.001mm, repeatability +/- 0.003mm	EV701*, EV702*, EV705*
FH-049-0014	Motorized CNC X-Y stage, 337x238 mm, total load up to 400Kgf max. Displacement: 200x150mm, resolution 0.001mm, repeatability +/- 0.003mm	EV701*, EV702*, EV705*
FH-049-0015	Motorized CNC X-Y stage, 437x238 mm, total load up to 450Kgf max. Displacement: 300x150mm, resolution 0.001mm, repeatability +/- 0.003mm	EV701*, EV702*, EV705*
FH-049-0016	Motorized CNC X-Y stage, 630x238 mm, total load up to 450Kgf max Displacement: 400x150mm, resolution 0.001mm, repeatability +/- 0.003mm	EV701*, EV702*, EV705*
FH-049-0017	Motorized CNC X-Y stage, 410x280 mm, total load up to 4000Kgf max. Displacement: 200x150mm, resolution 0.001mm, repeatability +/- 0.008mm	EV701*, EV702*, EV705*
FH-049-0018	Motorized CNC X-Y stage, 510x280 mm, total load up to 4000Kgf max. Displacement: 300x150mm, resolution 0.001mm, repeatability +/- 0.008mm	EV701*, EV702*, EV705*

Optional accessories

FH-049-0019	Motorized CNC X-Y stage, 630x238 mm, total load up to 4000Kgf max. Displacement: 400x150mm, resolution 0.001mm, repeatability +/- 0.008mm	EV701*, EV702*, EV705*
FH-050-0335	Dove tail mounting plate, for UN motorized stages	EV701*, EV702*, EV708*
FH-011-0045	Cable set for connecting CNC stage to embedded driver (1 set for 2-axis) 105cm	EV701*, EV702*
FH-002-0037	Cable set for connecting CNC stage to embedded driver (1 set for 2-axis) 155cm	EV705*
Anvils		
FH-050-0266	Flat anvil 60mm	EV701*, EV702*, EV708*
FH-050-0117	Flat anvil 80mm	EV701*, EV702*, EV708*
FH-050-0041	Spot anvil 5mm	EV701*, EV702*, EV708*
FH-050-0037	Spot anvil 10mm	EV701*, EV702*, EV705*, EV708*
FH-050-0324	Cylindrical V anvil 6-80mm	EV701*, EV702*, EV708*
FH-050-0325	Cylindrical V anvil 50-200mm	EV701*, EV702*, EV708*
FH-050-0353	V block with bracket 40x40x50mm (LxBxH)	EV701*, EV702*, EV705*, EV708*
FH-050-0354	Steel, cross type, (X) V-block 60x120x100mm 8-90mm pair	EV701*, EV702*, EV705*, EV708*
FH-050-0040	V-anvil ø40mm 6-60mm	EV701*, EV702*, EV708*
FH-050-0326	V-anvil ø63mm 10-100mm	EV701*, EV702*, EV708*
FH-050-0025	V-Anvil ø80mm 3.3-20mm	EV701*, EV702*, EV708*
FH-050-0026	V-Anvil ø80mm 12-80mm	EV701*, EV702*, EV708*
FH-050-0027	V-Anvil ø80mm 20-140mm	EV701*, EV702*, EV708*
FH-050-0123	V-anvil ø120mm 17-100mm	EV705*
FH-050-0124	V-anvil ø120mm 3.3-20mm	EV705*
FH-050-0125	V-anvil ø120mm 33-200mm	EV705*
FH-050-0034	Large flat surface testing table 650X500mm, thickness 45mm with 2 T-slots, for large components	EV705*
FH-050-0029	Test table 100x100mm, V groove 20mm wide, 10mm deep	EV701*, EV702*, EV708*
FH-006-1008	Small V-Anvil 3-20mm requires base plate (Req. Manual/Autom. X-Y stage)	EV701*, EV702*, EV705*, EV708*
FH-006-1009	Large V-Anvil 20-75mm requires base plate (Req. Manual/Autom. X-Y stage)	EV701*, EV702*, EV705*, EV708*

Optional accessories

FH-050-0267	Base plate for V-anvils	EV701*, EV702*, EV705*, EV708*
EV-ANV-0000	Extra long V-Anvil (Ø10 - Ø100)	EV701*, EV702*, EV708*
Fixtures/Vice		
FH-050-0340	Polished precision vice with lock, opening width 25mm, opens 20mm	EV701*, EV702*, EV705*, EV708*
FH-050-0341	Polished precision vice with lock, opening width 36mm, opens 42mm	EV701*, EV702*, EV705*, EV708*
FH-050-0342	Polished precision vice with lock, opening width 48mm, opens 75mm	EV701*, EV702*, EV705*, EV708*
FH-050-0343	Polished precision vice with lock, opening width 75mm, opens 100mm	EV701*, EV702*, EV705*, EV708*
EV-FNV-0000	Axle chuck 500 series for cylinder parts, dia. 0.4mm to 5mm	EV701*, EV702*, EV705*
FH-050-0073	Universal Clamp & Leveling Device	EV701*, EV702*, EV705*
FH-050-0076	Thin metal clamp	EV701*, EV702*, EV705*
FH-050-0345	V groove clamp for small round parts dia.0.8-5mm	EV701*, EV702*, EV705*
FH-050-0075	Wire Testing Fixture for specimen dia. 0.8-3.5mm	EV701*, EV702*, EV705*
FH-050-0112	JOMINY Fixture, for 1 quench end test sample, quick release function	EV701*, EV702*, EV705*, EV708*
FH-050-0113	JOMINY Fixture, for 3 quench end test sample, quick release function	EV701*, EV702*, EV705*, EV708*
EV-FNV-0001	Small parts vice jaw width 55mm, open 50mm, self centering	EV701*, EV702*, EV705*, EV708*
EV-FNV-0003	Jack Rest	EV708*
Sample holders		
FH-050-0268	1 position sample holder, for 1 embedded sample, diameter 50mm or 2"	EV701*, EV702*, EV705*, EV708*
FH-050-0269	4 position sample holder, for max. 4 embedded samples, Ø 50mm or 2"	EV701*, EV702*, EV705*, EV708*
FH-050-0270	6 position sample holder, for max. 6 embedded samples, Ø 50mm or 2"	EV701*, EV702*, EV705*, EV708*
EV-SHL-0000	1 position sample holder, for 1 embedded sample, diameter 50mm or 2" with front operation elevator knob	EV701*, EV702*, EV708*

Optional accessories

EV-SHL-0001	4 position sample holder, for 4 embedded sample, diameter 50mm or 2" with front operation elevator knob	EV701*, EV702*, EV708*
EV-SHL-0002	6 position sample holder, for 6 embedded sample, diameter 50mm or 2" with front operation elevator knob	EV701*, EV702*, EV708*
EV-SHL-0003	12 position sample holder, for 12 embedded sample, diameter 50mm or 2" with front operation elevator knob	EV701*, EV702*, EV708*
EV-SHL-0004	1 insert reduction ring 25mm	EV701*, EV702*, EV705*, EV708*
EV-SHL-0005	1 insert reduction ring 30mm	EV702*, EV705*, EV708*
EV-SHL-0006	1 insert reduction ring 40mm	EV701*, EV702*, EV705*, EV708*
FH-050-0307	1 insert reduction ring 1"	EV701*, EV702*, EV705*, EV708*
FH-050-0308	1 insert reduction ring 1¼"	EV701*, EV702*, EV705*, EV708*
FH-050-0309	1 insert reduction ring 1, 5"	EV701*, EV702*, EV705*, EV708*
Software		
FH-006-1011	Advanced 3 axis coordinate & free style indent pattern congrator, for motorized stage only	EV701*, EV702*, EV708*
FH-500-0021	Advanced 3 axis coordinate & free style indent pattern congrator, + CHD, SHD, NHD and edge detection, (supports manual & digital micrometer stages only)	EV701*, EV702*
FH-500-0022	Image stitching, composes full stage overview, and detailed sample overview in high resolution. Req. a motorized stage.	EV701*, EV702*, EV708*
FH-006-1016	KiC crack detection under load. Palmqvist & Median / Radial fracture toughness	EV701*, EV702*, EV708*
FH-500-0023	Automatic Contour scanning	EV701*, EV702*, EV708*
FH-500-0012	2D / 3D hardness scanning (mapping, includes automatic contour scanning)	EV701*, EV702*, EV708*
FH-500-0024	Drawing and measuring (distance & angles) application	EV701*, EV702*, EV708*
EV-ASW-0001	DualView Technology, 2 viewing screens software, screen, cables, Europe and US power cable included, 24" Industrial LCD screen included	EV701*
FH-050-0203	Automatic edge detection	EV701*, EV702*, EV708*
FH-500-0026	Force depth/time diagram	EV701*, EV702*, EV708*
FH-500-0027	ISO898-1 screw thread measurement of (de)-carbonized part	EV701*, EV702*, EV708*

Optional accessories

FH-500-0028	ISO-2702 tap screw thread measurement	EV701*, EV702*, EV708*
EV-ASW-0003	User level management	EV701*, EV702*, EV708*
FH-500-0029	CHD, SHD, NHD congrator & graphic interface for analogue and digital micro meter stage only (not including full pattern editor)	EV701*, EV702*
FH-006-1012	CHD, SHD, NHD congrator & graphic interface requires: indent pattern congrator	EV701*, EV702*, EV708*
FH-500-0030	Q-DAS Certied connectivity protocol	EV701*, EV702*, EV708*
EV-ASW-0005	Advanced 3-axis communication protocol for robotic systems	EV701*, EV702*, EV708*
FH-006-1013	ISO bullets casings pattern congrator and reporting system	EV701*, EV702*, EV708*
FH-006-1018	ISO 9015 Weld pattern configurator (automatic weld pattern congrator), requires overview camera	EV701*, EV702*, EV708*
EV-ASW-0006	Vibration, temperature & humidity monitoring	EV701*, EV702*, EV708*
EV-ASW-0007	Barcode & QR data mapping software	EV701*, EV702*, EV708*
EV-ASW-0008	Metalloscope™ Metalloggy software pack	EV701*
FH-500-0031	Articial Intelligence Deep Learning Brinell module	EV701*, EV702*, EV708*
FH-053-0007	Powerful external intel core i7 pc, with 16gb ram, and 512gb ssd drive Windows 10 pre-installed including wiring and integration with tester.	EV701*, EV702*, EV708*
FH-053-0008	Powerful external intel core i9 pc, with 16GB ram, and 512GB SSD drive Windows 10 pre-installed including wiring and integration with tester	EV701*, EV702*, EV708*
FH-500-0019	Bluetooth connectivity	EV701*, EV702*, EV708*
FH-050-0119	Utility software; Import test results in MS applications like Excel	EV701*, EV702*, EV708*
EV-SYS-0001	Application of customer supplied PC, plus wiring and integration with tester	EV708*
EV-SYS-0002	USB to USB null modem cable 2.5M	EV701*, EV702*, EV708*
FH-050-0136	Wireless system Keyboard & wireless mouse	EV701*, EV702*, EV708*
Cover		
FH-052-0008	Tester cover 60x70x100cm	EV701*, EV702*
FH-052-0011	Tester cover 80x115x210cm	EV705*

Optional accessories

Tables/Cabinets

FH-095-0002	Cabinet/table for bench machines 710x750x800mm (grey/black top)	EV701*, EV702*
FH-095-0003	Cabinet/table for bench machines 1500x750x800mm (grey/black top)	EV701*, EV702*

Calibration options

FH-051-0000	Direct calibration; ISO 17025-A2LA compliant/per scale (factory)	EV701*, EV702*, EV705*, EV708*
FH-051-0002	Additional scales calibration	EV701*, EV702*, EV705*, EV708*
FH-051-0005	VICKERS direct and indirect verification/calibration & certification in compliance with ISO & ASTM, NADCAP. Includes direct force and indirect verification report (block readings), GR & R report	EV701*, EV702*, EV705*, EV708*
FH-051-0006	BRINELL direct and indirect verification/calibration & certification in compliance with ISO & ASTM, NADCAP. Includes direct force and indirect verification report (block readings), GR & R report	EV701*, EV702*, EV705*, EV708*
FH-051-0007	KNOOP direct and indirect verification/calibration & certification in compliance with ISO & ASTM, NADCAP. Includes direct force and indirect verification report (block readings), GR & R report	EV701*, EV702*, EV705*, EV708*
FH-051-0008	ROCKWELL direct and indirect verification/calibration & certification in compliance with ISO & ASTM, NADCAP. Includes direct force and indirect verification report (block readings), GR & R report	EV701*, EV702*, EV705*, EV708*

Additional items

FH-050-0289	Passive vibration isolation stage, broad spectrum	EV701*, EV702*
FH-053-0009	Dust Protection System	EV705*
EV-JST-0000	3-axis joystick, with ne adjustment and dynamic axis control	EV701*



Universal Hardness Testing System

www.tiniusolsen.com

- + Horsham, PA, USA
- + Redhill, Surrey, UK
- + Noida, UP, India
- + Shanghai, PR China
- + Dubai, UAE